

Code 353120 F  
Printed in Singapore



**olivetti**



19



# **ET PERSONAL 55**

User Manual



**olivetti**

**PUBLICATION ISSUED BY:**

Ing. C. Olivetti & C., S.p.A.  
Direzione Documentazione  
77, Via Jervis - 10015 Ivrea (Italy)

*Copyright © 1987, by Olivetti  
All rights reserved*

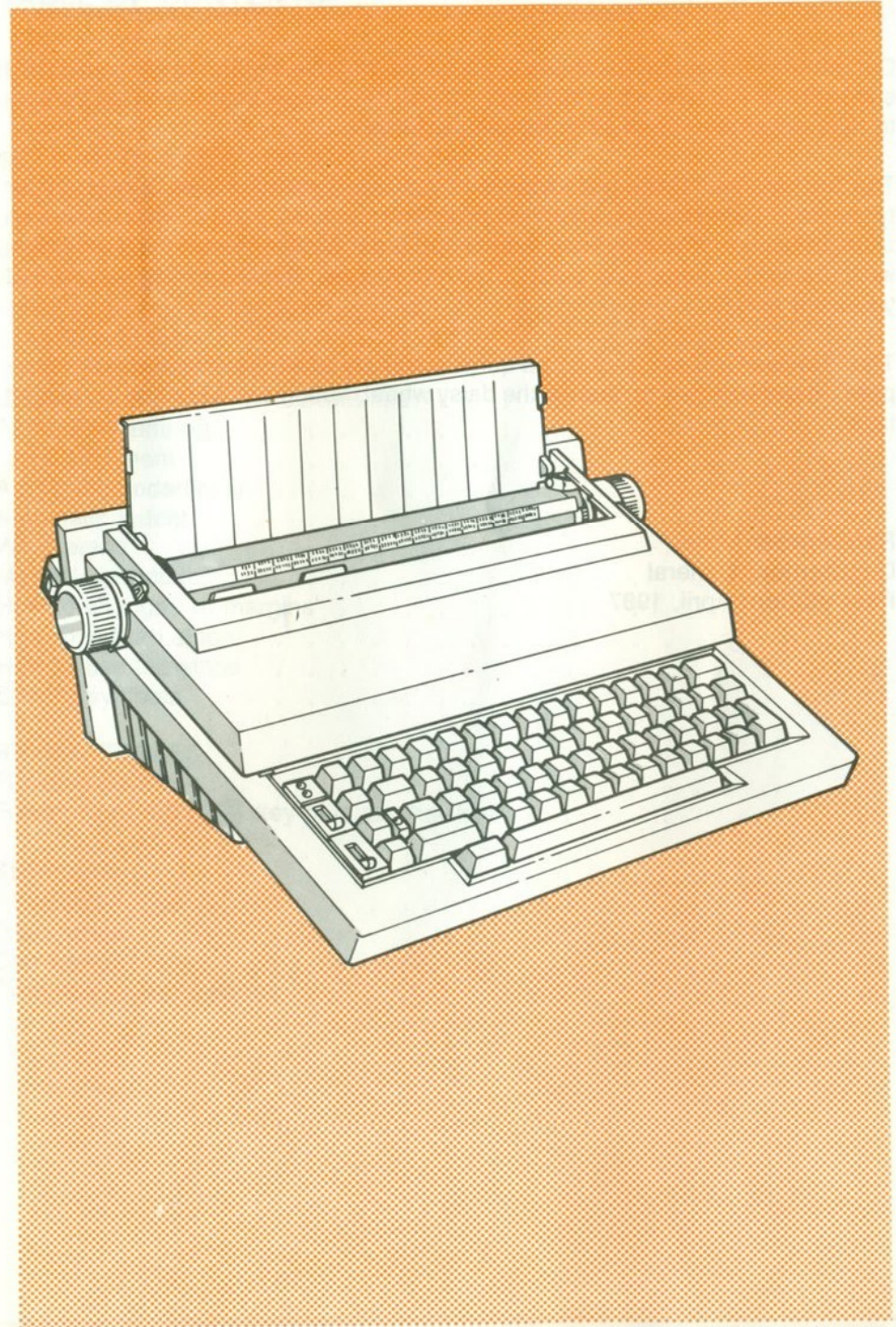

Information from  
Olivetti Documentation

## FOREWORD

---

Congratulations on the purchase of your new portable electronic typewriter. We suggest that you take a few moments to read the manual so that you will be able to take advantage of all of its special features.

The first section, "Getting to know your typewriter", describes each part of your typewriter. "Using the typewriter" is divided into modules, each of which describes a single feature. You may read them in the order given here or in any order you wish, using the index as a guide. This lets you skip directly to the feature that you want to use.

The "Review Tables" give you a quick summary of all the special keys; "Supplies" describes how to change the daisy wheel, ribbon cartridge and correcting tape.

**References:** None  
**Distribution:** General  
**First edition:** April, 1987

## TABLE OF CONTENTS

---

<b>INTRODUCTION</b>	
Introduction . . . . .	7
<b>GETTING TO KNOW THE TYPEWRITER</b>	
Getting to know the typewriter . . . . .	9
<b>USING THE TYPEWRITER</b>	
Getting the most out of the manual . . . . .	19
How to turn the typewriter on and off . . . . .	20
Beginning to type . . . . .	21
Correcting the last typed character . . . . .	22
Correcting errors on the current line . . . . .	23
Automatic centring . . . . .	24
Right alignment . . . . .	25
Automatic underlining . . . . .	26
Automatic indent . . . . .	27
Word erase . . . . .	28
Manual corrections . . . . .	29
How to change the margins . . . . .	30
How to set tab stops . . . . .	31
How to use tab stops . . . . .	32
Special symbols . . . . .	33
<b>REVIEW TABLES</b>	
Function keys . . . . .	35
Functions of the <b>CODE</b> key plus another key . . . . .	36
<b>SUPPLIES</b>	
Ribbon cartridge . . . . .	37
Daisy wheel . . . . .	39
Correcting tape . . . . .	43
Technical specifications . . . . .	46

## GETTING TO KNOW YOUR TYPEWRITER

### ON/OFF Switch

The on/off switch is on the left side of the typewriter. The two positions are I for on and O for off.

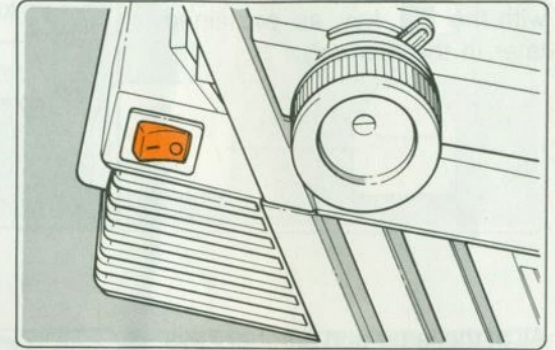

### Keyboard

The keyboard is divided into an alphanumeric key section and a function key section.

### ALPHANUMERIC KEYS

These are the standard letter and number keys.

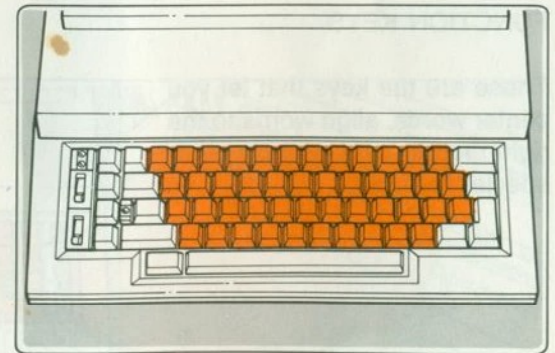

You'll note that several keys contain more than two symbols. You may print the symbols on the right by pressing the key together with the **KB** key as explained later in the manual.

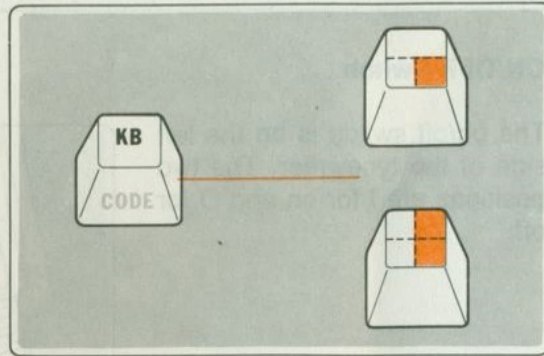

All of the letter and number keys repeat automatically if you hold them down.

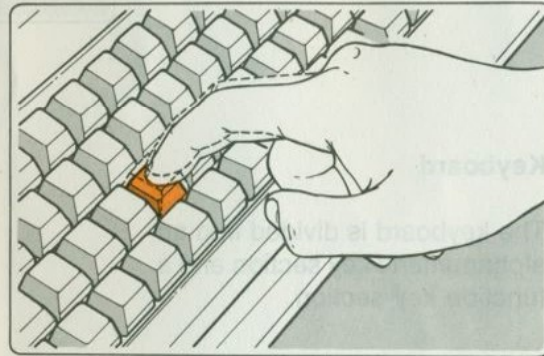

## FUNCTION KEYS

These are the keys that let you center words, align words to the right margin, and perform other special features.

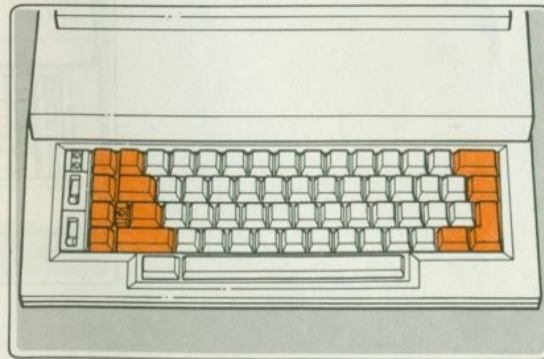

Depending on what you want to do, you either press the function key by itself or press it together with the **CODE** key. The **CODE** key is the key that has **KB** on the top and **CODE** on the front.

For a quick look at all of the function keys, see the "Function Keys" chart in the Review Tables section.

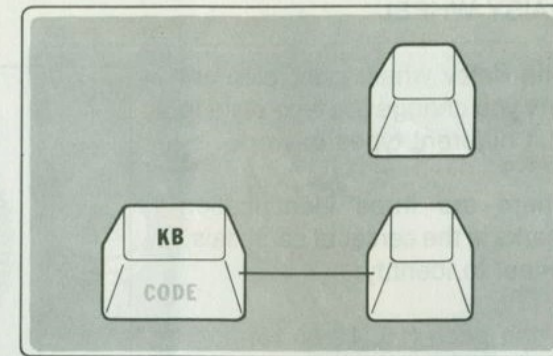

Several of the function keys are automatic repeat keys.

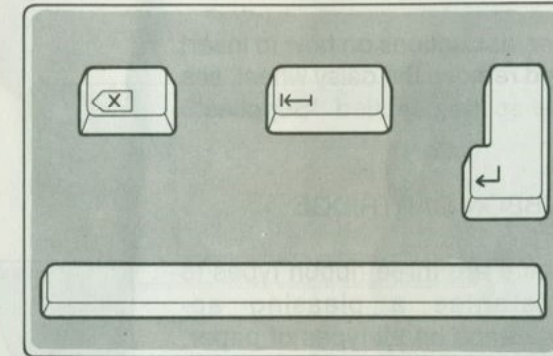

## Print unit

The print unit incorporates the daisy wheel, ribbon cartridge and correcting tape. It slides along the platen to print the characters that you type.

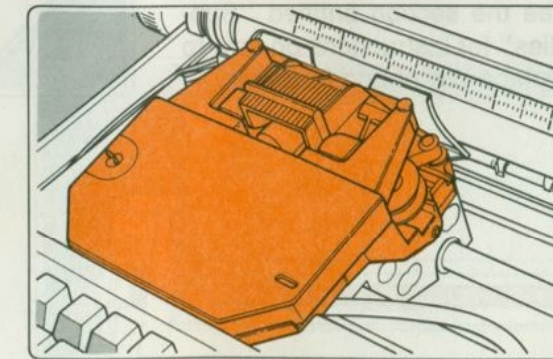

## DAISY WHEEL

The daisy wheel print element lets you change the type style to suit different types of work.

There are three identification marks in the center of each daisy wheel to identify:

- the pitch (10, 12 or 15)
- the type style (pica, elite)
- the three-digit national keyboard code.

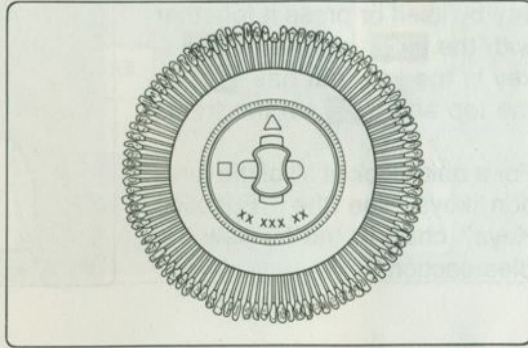

For instructions on how to insert and remove the daisy wheel, see the section entitled "Supplies".

## RIBBON CARTRIDGE

There are three ribbon types to guarantee a pleasing appearance on all types of paper.

- fabric (green)
- carbon (red)
- correctable carbon (yellow)

See the section entitled "Supplies" for instructions on how to replace the ribbon cartridge.

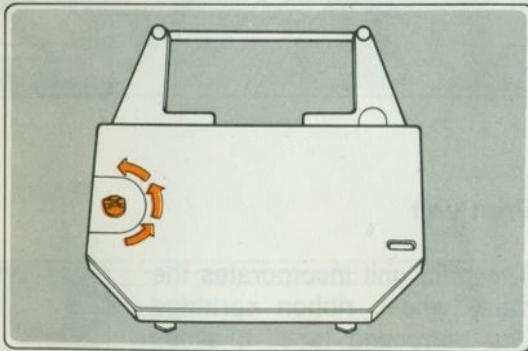

## CORRECTING TAPE

LIFT-OFF (yellow) can be used only with a correctable carbon ribbon. It lifts the incorrect character off the paper.

COVER-UP (orange) is used with fabric or carbon ribbon. It covers the error with a chalky substance so that you can type over it.

See the section entitled "Supplies" for instructions on how to replace the correcting tape.

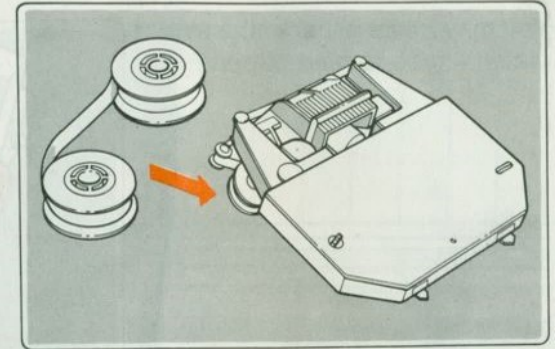

## Platen and writing line

The platen is 11.8 inches long and permits a writing line of up to 9 inches. The maximum number of characters per line depends on the pitch (characters/inch) you are using.

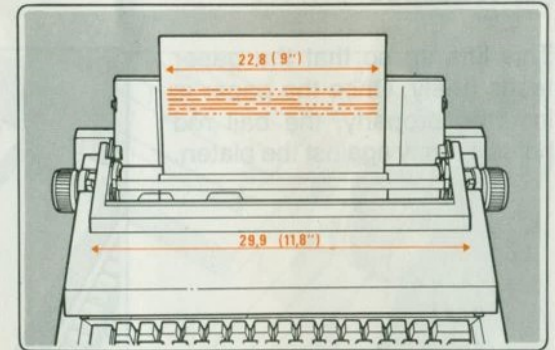

## Graduated scales

These identify the exact position of the print unit.

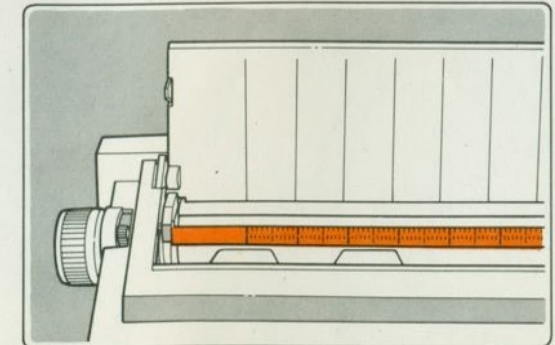

### Platen knobs

You may rotate either of the two platen knobs to feed paper.

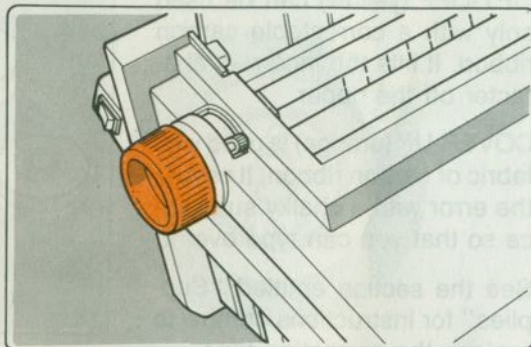

### Paper bail rod

This lifts up so that the paper feeds freely. Once the paper is inserted properly, the bail rod holds it firmly against the platen.

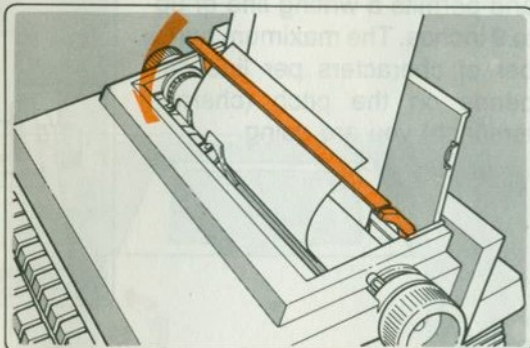

### Paper guide

This establishes an exact position for the left edge of the paper so that each sheet is inserted in the same position.

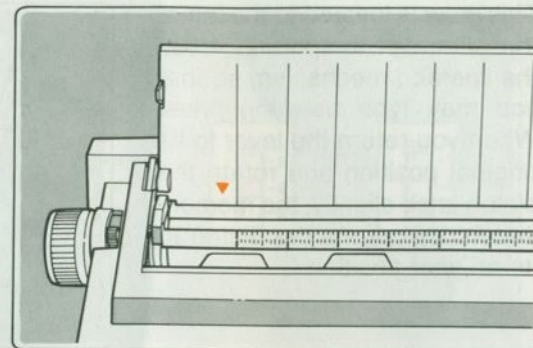

### Paper release lever

This lever is located to the right of the platen. When you push it forward it frees the paper so that you may align it manually.

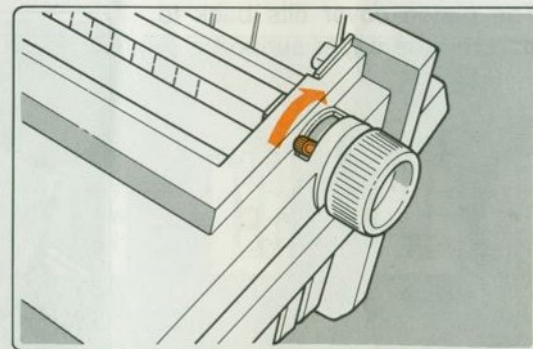

### Memory line finder

This lever is located to the left of the platen. It temporarily frees the linefeed mechanism so that you may type between lines. When you return the lever to its original position and rotate the platen knob slightly, the memory line finder returns the platen to its original position.

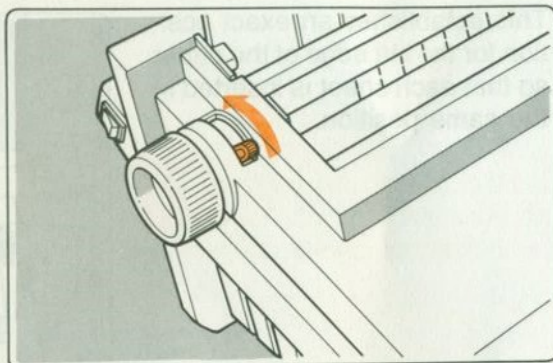

### Paper support

The platen cover tilts back to become the paper support.

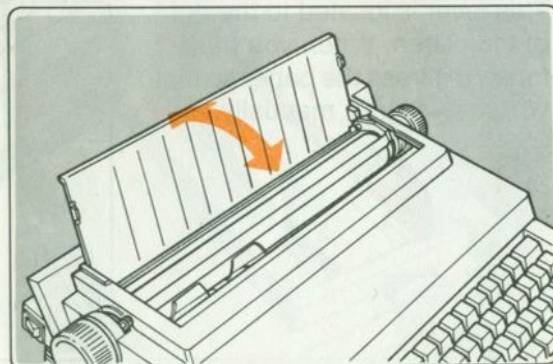

### Pitch Selector

You may change the position of this selector before you begin to type or after a carriage return. The three positions are:

- 10: 10 characters/inch (Pica)
- 12: 12 characters/inch (Elite)
- 15: 15 characters/inch (Mikron)

Make sure that the position of the pitch selector matches the pitch indicated on the daisy wheel.

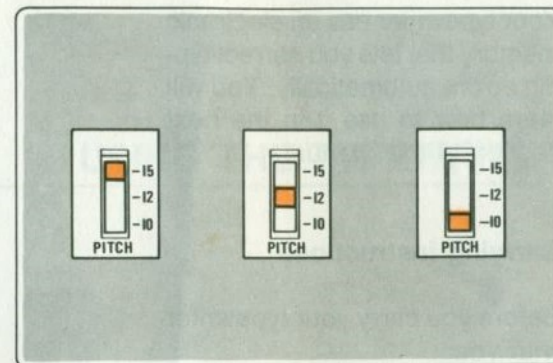

### Linefeed selector

- 1: single spacing
- 1½: one-and-a-half spacing
- 2: double spacing

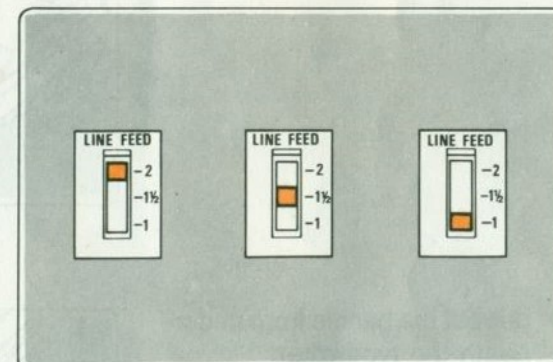



## Memory

Your typewriter has an electronic memory that lets you correct typing errors automatically. You will learn how to use it in the next section of the manual.

## Carrying instructions

Before you carry your typewriter with you:

- replace the keyboard cover

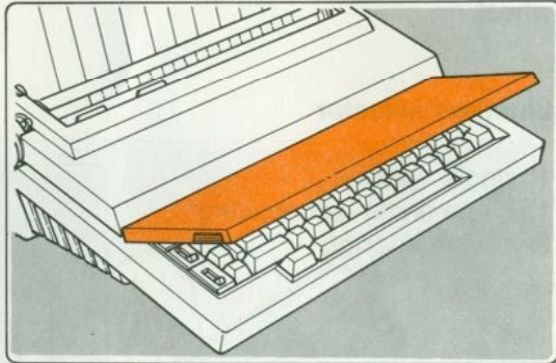

- pull out the handle from underneath the typewriter.

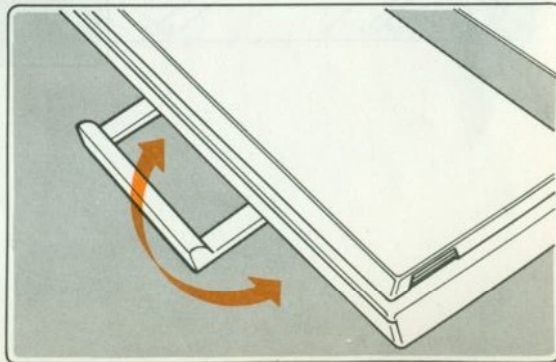

## USING THE TYPEWRITER

## GETTING THE MOST OUT OF THE MANUAL

This part of the manual is made up of individual modules. Each one describes a special feature of your typewriter. You may read them in any order you wish, skipping to the ones you need. The modules are structured like this:

### FEATURE NAME AND KEYS USED

A brief description of the feature follows the title. This tells you immediately if it is the one you want and exactly what you will learn.

- The black square alerts you to any conditions that must exist before you begin. If there are no special conditions, there is no text here.

1	This column gives step by step instructions for you to follow such as the <b>KEYS</b> you must press.	This column describes what the typewriter does.	<i>This column gives additional information that might be helpful — such as what to do if you make a mistake. Very often there is no text in this column.</i>
2	When a step consists of alternative operations, they will be indicated with dashes like this:  - Select the first one,  or  - Select the second one.		

## HOW TO TURN THE TYPEWRITER ON AND OFF

You must turn the typewriter on each time you use it.

- You have removed the power cord from the back of the typewriter and plugged it into an electrical outlet.

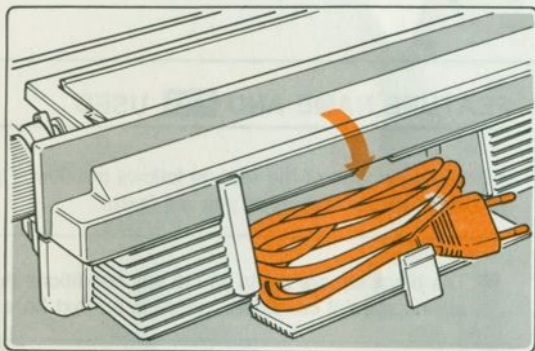



<p>1 Turn the switch on the left of the typewriter to the I (on) position.</p>	<p>The I/ON light flashes and the print unit slides to the left margin. When the light stops flashing, it means that the typewriter is ready for use.</p>	<p><i>There is an electronic demonstration built into your typewriter that lets you see some of the special things it can do.</i></p> <p><i>If you want to see it work, first turn the typewriter off and insert a sheet of paper. Then press the <b>1</b>, <b>2</b> and <b>3</b> keys together and, at the same time, turn the typewriter on.</i></p>
<p>2 To turn the typewriter off, turn the switch to the O (off) position.</p>		

## BEGINNING TO TYPE

Each time you turn the typewriter on, the left and right margins are set to provide a standard line length. This means that you may begin typing immediately.

- The typewriter is plugged in and turned on.

<p>1 Insert a sheet of paper, aligning the left edge with the triangle on the paper support.</p>		
<p>2 Set the pitch selector to match the pitch on the daisy wheel you are using.</p>		
<p>3 Set the linefeed selector for single, one-and-a-half or double spacing.</p>		
<p>4 Begin typing, pressing  at the end of each line.</p>	<p>The print unit moves as you type and returns to the left margin of the next line when you press .</p> <p>The standard line is six inches long, with five tab stops and with the bell set to ring eight spaces from the right margin.</p>	<p><i>To type capital letters, hold down one of the <b>SHIFT</b> keys while you type the character. You may lock the upper case letters in place by pressing <b>LOCK</b>.</i></p> <p><i>To unlock the upper-case keyboard, press <b>SHIFT</b>.</i></p> <p><i>If you want to change the margins, see the module entitled "How to change the margins".</i></p> <p><i>If you want to change the tab stop positions, see the module entitled "How to set tab stops".</i></p>

## CORRECTING THE LAST TYPED CHARACTER

The last 80 characters on the current line are always stored in the memory so that you may correct any typing errors automatically. Each time you press the **←** key, the memory clears. This module explains how to correct the last typed character. The next one explains how to correct the other characters on the line.

- You have just typed an incorrect character and haven't pressed the space bar. There is a spool of correcting tape in the print unit.

<p>1 Press <b>←</b> .</p>	<p>The print unit backspaces once and erases the character.</p>	<p><i>If you are using COVER-UP correcting tape, press <b>CODE</b> <b>E</b> before you press <b>←</b> .</i></p> <p><i>If you pressed the space bar after typing the incorrect character, you must follow the instructions in the next module to correct it.</i></p>
---------------------------	-----------------------------------------------------------------	---------------------------------------------------------------------------------------------------------------------------------------------------------------------------------------------------------------------------------------------------------------------

## CORRECTING ERRORS ON THE CURRENT LINE

You may automatically erase up to 80 characters on the current line. Each time you press **←** , the memory empties to make room for the next line.

- There is an error on the current line and there is a spool of correcting tape in the print unit.

<p>1</p>	<p>Press the <b>←</b> key to position the print unit on the incorrect character. If you want to erase more than one character, keep in mind that the typewriter erases from right to left.</p>		<p><i>If the character to be erased is near the left margin, you may return to the left margin by pressing <b>CODE</b> <b>RELOC</b> .</i></p>
<p>2</p>	<p>Press <b>←</b> .</p>	<p>The character is erased.</p>	<p><i>If you want to erase more than one character, hold the <b>←</b> key down.</i></p> <p><i>If you exceed the memory capacity, the typewriter beeps and you may make additional corrections manually, following the instructions in the module entitled "Manual corrections".</i></p>
<p>3</p>	<p>Type the correct character or characters.</p>		
<p>4</p>	<p>Press <b>RELOC</b> .</p>	<p>The print unit returns to where it was at the beginning of the procedure.</p>	

## AUTOMATIC CENTRING **CODE—C**

You may centre a word or words automatically between the margins. The characters that you want to centre don't print immediately; they are stored temporarily and print at the end of the procedure.

■ You have just turned the typewriter on or have just pressed **↵**.

<p>1 Press <b>CODE—C</b> .</p>	<p>The "EDIT" light blinks to alert you that the characters you are about to type will not print immediately.</p>	<p><i>You may cancel the centring command by pressing <b>⌫</b> .</i></p> <p><i>If the typewriter beeps, it means you didn't press <b>↵</b> before pressing <b>CODE—C</b> .</i></p> <p><i>Press <b>↵</b> and begin the procedure again.</i></p>
<p>2 Type the characters that you want to centre (up to 80).</p>	<p>The characters are stored in the typewriter memory.</p>	<p><i>If you make a mistake, press <b>⌫</b> once to erase all of the characters you typed and then retype them.</i></p> <p><i>If you type more than 80 characters, the typewriter beeps. Press <b>⌫</b> once and retype the characters.</i></p>
<p>3 Press:</p> <p>- <b>↵</b></p> <p>- <b>RELOC</b></p>	<p>The centred words print and the print unit goes to the beginning of the next line.</p> <p>The centred words print and the print unit remains on the space following the last printed character.</p> <p>The "EDIT" light goes off.</p>	<p><i>If you see that you have made a mistake, see the module entitled "Manual corrections".</i></p> <p><i>If you see that you have made a mistake, you may correct it automatically as described in the module entitled "Correcting errors on the current line".</i></p>

## RIGHT ALIGNMENT **CODE—G**

You may automatically align a word or words to the right margin. The characters don't print immediately; they are stored temporarily and print at the end of the procedure.

■ You have just turned the typewriter on or have just pressed **↵**.

<p>1 Press <b>CODE—G</b> .</p>	<p>The EDIT light blinks to alert you that the characters you are about to type will not print immediately.</p>	<p><i>You may cancel the right alignment command by pressing <b>⌫</b> .</i></p> <p><i>If the typewriter beeps, it means you didn't press <b>↵</b> before pressing <b>CODE—G</b> .</i></p> <p><i>Press <b>↵</b> and begin the procedure again.</i></p>
<p>2 Type the characters that you want to align (up to 80).</p>	<p>The characters are stored in the typewriter memory.</p>	<p><i>If you make a mistake, press <b>⌫</b> once to erase all of the characters you typed and then retype them.</i></p> <p><i>If you type more than 80 characters, the typewriter beeps. Press <b>⌫</b> once and retype the characters.</i></p>
<p>3 Press:</p> <p>- <b>↵</b></p> <p>- <b>RELOC</b></p>	<p>The right aligned text prints and the print unit goes to the beginning of the next line.</p> <p>The right aligned text prints and the print unit remains on the space following the last printed character.</p> <p>The EDIT light goes off.</p>	<p><i>If you see that you have made a mistake, see the module entitled "Manual corrections".</i></p> <p><i>If you see that you have made a mistake, you may correct it automatically as described in the module entitled "Correcting errors on the current line".</i></p>

# AUTOMATIC UNDERLINING **CODE—X**

In addition to the conventional underline key that lets you underline printed characters, you may use the "automatic underline" feature to print an underlined character.

1	Press <b>CODE—X</b> .		
2	Type the characters that you want to underline.	The underlined characters print.	<i>The underline symbol is stored together with the character. If you erase the character, the underline is erased as well.</i>
3	Press <b>CODE—X</b> again.	The underline condition goes off.	
4	Continue typing normally.		

# AUTOMATIC INDENT **CODE—MARGIN LEFT** , **↵**

This feature lets you automatically indent a line one inch from the left margin.

■ You are at the end of the line preceding the one you want to indent.

1	Press <b>CODE—MARGIN LEFT</b> .		
2	Press <b>↵</b> .	The print unit goes to a position one inch from the left margin of the next line.	
3	Continue typing normally.		

## WORD ERASE **CODE**

This module explains how you may erase an entire word with a single command.



- The word you want to erase is on the current line and you have a spool of correcting tape in your typewriter.

1	Use the <b>⬅</b> key to position the print unit anywhere on the word to be erased.		<p><i>If you want to erase the word you just typed and you haven't yet pressed the space bar, you may go directly to step 2.</i></p> <p><i>If the typewriter beeps, it means that the word is no longer stored in the memory and you must make the correction manually.</i></p>
2	Press <b>CODE</b>  .	The word is erased.	
3	Type, if you wish, the correct word.		<p><i>If the new word is one character longer than the one you erased you may backspace a half space to fit it in by pressing <b>CODE</b> <b>⬅</b> .</i></p> <p><i>If you want to erase the new word, you must do it manually.</i></p>
4	Press <b>RELOC</b> .	The print unit returns to where it was when you began the procedure.	

## MANUAL CORRECTIONS

If you want to correct errors that are no longer stored in the memory, you may do it manually as explained here.

- There is a spool of correcting tape in the print unit.

1	Position the print unit on the incorrect character.		<p><i>To erase an underlined character:</i></p> <ul style="list-style-type: none"> <li>• Press  .</li> <li>• Type the incorrect character.</li> <li>• Press  .</li> <li>• Type an underline.</li> </ul>
2	Press  .		
3	Type the incorrect character.	The character is erased.	
4	Repeat steps 1-3 for each incorrect character.		
5	Type the correct characters.		

## HOW TO CHANGE THE MARGINS

You may adjust the margin positions to lengthen or shorten the writing line.

1	Use the space bar or the <b>←</b> key to move the print unit to the new left margin position and press <b>MARGIN LEFT</b> .	The new left margin replaces the old one.	<i>You may bypass the existing left margin by pressing <b>CODE</b> — <b>MARGIN LEFT</b>.</i>
2	Use the space bar to move the print unit to the new right margin position and press <b>MARGIN RIGHT</b> .	The new right margin replaces the old one and the bell is set to ring eight spaces from the right margin.	<i>You may bypass the existing right margin by pressing <b>CODE</b> — <b>MARGIN LEFT</b>.</i>
3	Press <b>↵</b> .	The print unit slides to the new left margin.	<i>You may cancel both margins at once by pressing <b>CODE</b> — <b>TAB CLEAR</b>.</i>

## HOW TO SET TAB STOPS

You may set up to ten tab stops. You may use them to indent lines to a given point or to align words or numbers in columns. You may also set special tab stops that automatically print a vertical line (|). This lets you use your typewriter to create charts and tables.

■ You have just turned the typewriter on or have just pressed **↵**.

1	Press the space bar to move the print unit to the position where you want to set a tab stop.		
2	Press: - <b>TAB SET</b> to set a normal tab stop. - <b>CODE</b> — <b>TAB SET</b> to set a vertical line tab stop.		<p><i>To clear a tab stop, press <b>→</b> to reach it and then press <b>TAB CLEAR</b>.</i></p> <p><i>To clear a vertical line tab stop, press <b>CODE</b> — <b>→</b> to reach it and then press <b>↵</b> followed by <b>TAB CLEAR</b>.</i></p> <p><i>If you try to set a tab stop on or outside a margin, the typewriter beeps.</i></p>
3	Repeat steps 1 and 2 for each tab stop.		



## HOW TO USE TAB STOPS

Once you have set tab stops, you may use them to align words, to align numbers on the decimal point, or to print vertical lines.

- You have set the tab stops that you need.





1	<p>Press:</p> <ul style="list-style-type: none"> <li>- <b>→ </b> if you want to align words at the tab stop position</li> <li>- <b>CODE → </b> if you want to align numbers on the decimal point.</li> </ul>	<p>The print unit slides to the first tab stop and the EDIT light blinks.</p>	<p><i>If it's a vertical line tab stop, the vertical line prints.</i></p>
2	<p>Type any words or numbers that you want to align.</p>	<p>If you pressed <b>→ </b>, the words print right away. If you pressed <b>CODE → </b> and type a decimal number, the whole number part and the decimal point print when you type the decimal point. The decimal part prints immediately.</p> <p>If you type a whole number, the number is stored and doesn't print until the next step.</p>	<p><i>If you want to cancel any of the stored characters, press <b>←X</b>.</i></p>
3	<p>Repeat step 1 to access another tab stop or press <b>↵</b> to go to the next line.</p>		

## SPECIAL SYMBOLS **KB**

Several of the keys on your typewriter have more than two symbols. The ones on the left are the ones that print when you press them by themselves. You may print the symbols on the right by pressing the key together with the **KB** key.

1	<ul style="list-style-type: none"> <li>- If you want to print the symbol on the lower right of the keytop, press <b>KB</b> together with the key.</li> <li>- If you want to print the symbol on the upper right of the key, press the <b>SHIFT LOCK</b> key first and then press <b>KB</b> together with the key.</li> </ul>	<p>The character prints.</p> <p>The shift lock light goes on and the character prints.</p>	<p><i>You may set the keyboard to always print the symbols on the right by pressing <b>KB</b> together with the shift lock key. The EDIT light goes on. To restore the symbols on the left, press <b>KB</b> and shift lock again. The EDIT light goes off.</i></p>
---	------------------------------------------------------------------------------------------------------------------------------------------------------------------------------------------------------------------------------------------------------------------------------------------------------------------------------	--------------------------------------------------------------------------------------------	--------------------------------------------------------------------------------------------------------------------------------------------------------------------------------------------------------------------------------------------------------------------

## FUNCTION KEYS

KEY	WHAT IT DOES
<b>MARGIN LEFT</b>	Sets the left margin.
<b>MARGIN RIGHT</b>	Sets the right margin.
<b>TAB SET</b>	Sets a tab stop.
	Moves the print unit to the next tab stop.
<b>LOCK</b>	Locks the upper case keyboard. The light goes on when you press the key.
<b>TAB CLEAR</b>	Cancel a tab stop.
<b>RELOC</b>	Moves the print unit to the space following the last printed character.
<b>KB</b>	Prints the symbols to the right of the keytop.
<b>space bar</b>	Moves the print unit forward one space.
	Moves the print unit backward one space.
	Erases the character or command.
	Returns the print unit to the left margin of the next line.

**FUNCTIONS OF THE CODE KEY PLUS ANOTHER KEY**

KEY COMBINATION	WHAT IT DOES
CODE — C	Centres words between margins.
CODE — G	Aligns words at the right margin.
CODE — TAB SET	Sets a vertical line tab stop.
CODE — TAB CLEAR	Cancels an entire line format (margins and tab stops).
CODE — →	Aligns numbers on the decimal point.
CODE —  ←	Backspaces the print unit in half steps.
CODE — ✕	Erases a word automatically.
CODE — RELOC	Moves the print unit to the beginning of the current line.
CODE — MARGIN RIGHT	Moves the print unit to the center of the platen for replacing the daisy wheel.
CODE — X	Underlines automatically.
CODE — L	Sets minimum impact.
CODE — H	Sets maximum impact.
CODE — E	Used in erasing with COVER-UP correcting tape.
CODE — MARGIN LEFT	Overrides the margin.

**SUPPLIES**

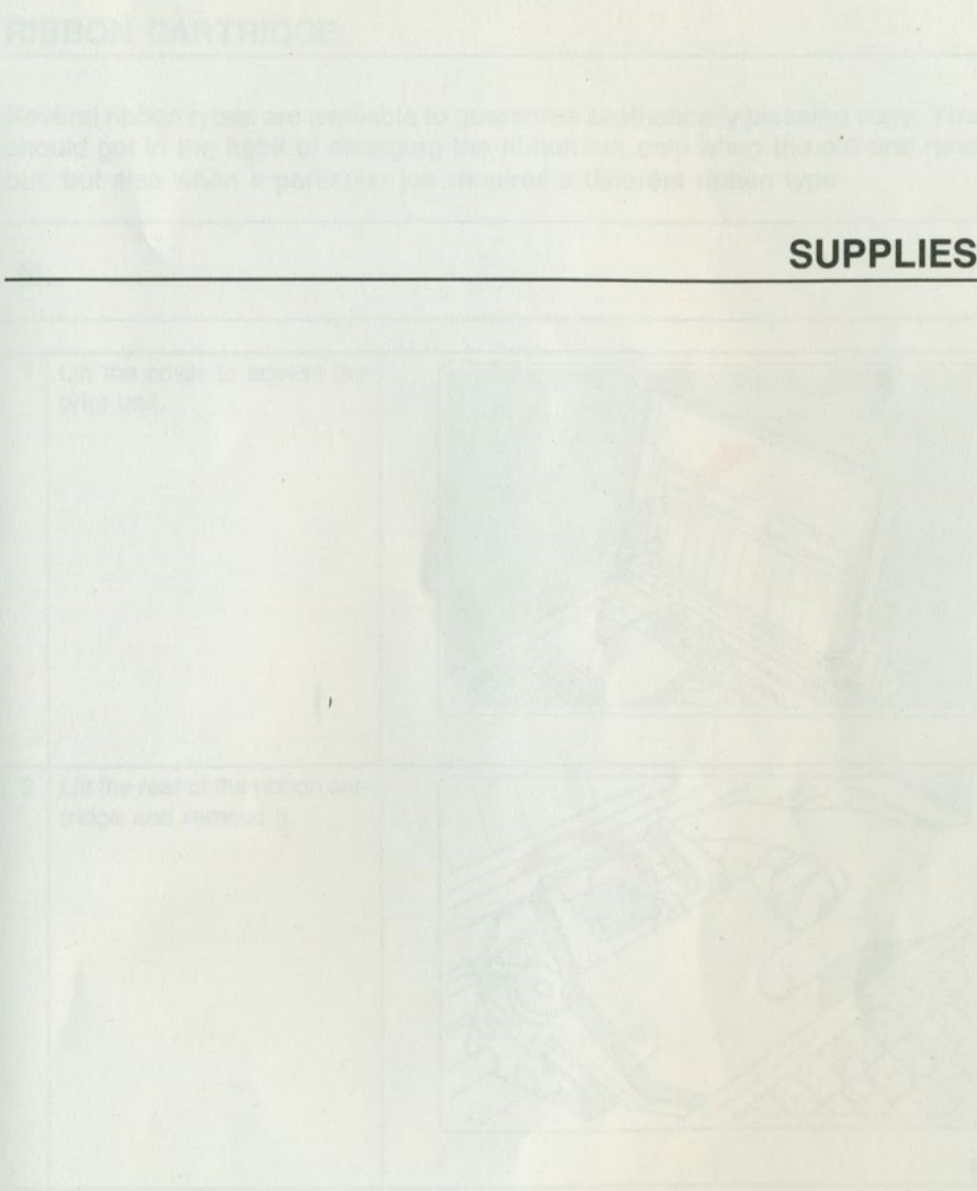

## RIBBON CARTRIDGE

Several ribbon types are available to guarantee aesthetically pleasing copy. You should get in the habit of changing the ribbon not only when the old one runs out, but also when a particular job requires a different ribbon type.

- 1 Lift the cover to access the print unit.

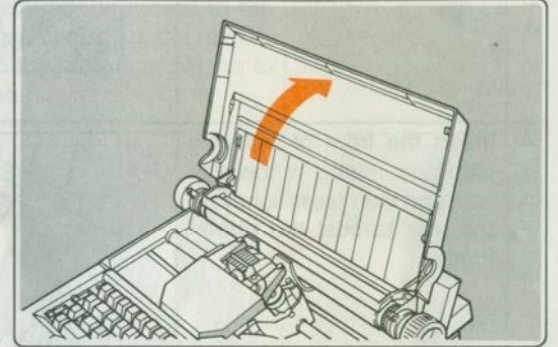

- 2 Lift the rear of the ribbon cartridge and remove it.

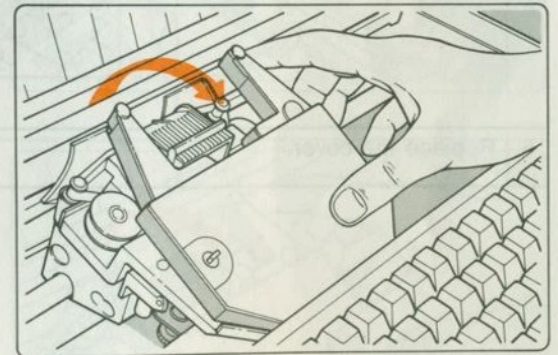

3 Turn the colored knob of the new cartridge slightly until the ribbon is taut.

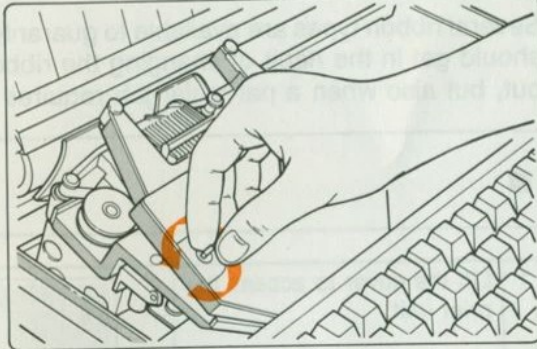

4 Insert the front of the new cartridge, tilting it towards you, and then press lightly on the rear to seat the ribbon firmly.

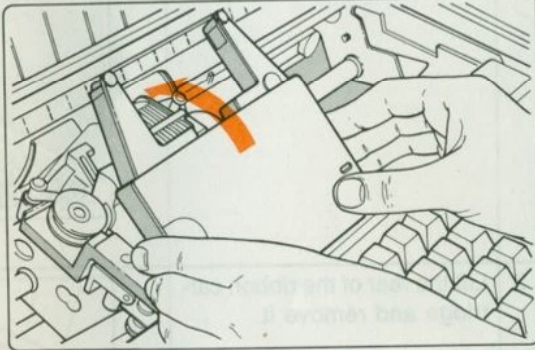

5 Replace the cover.

## DAISY WHEEL

You may change the character style or print pitch at any time by selecting one of the many daisy wheels available. A special command is used to move the print unit to the centre of the platen so that you may change the daisy wheel easily.

■ The typewriter is turned on.

1 Press **CODE**—**MARGIN RIGHT**. The print unit moves to the exact centre of the platen and the I/ON light begins to flash.

2 Lift the typewriter cover.

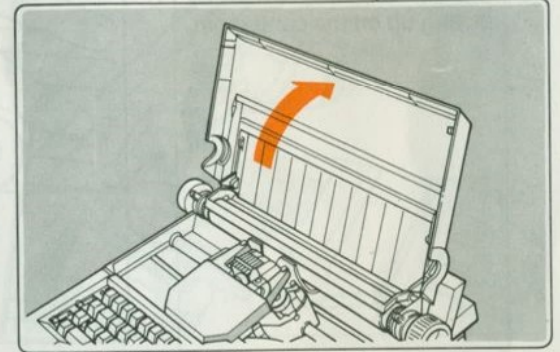

3 Remove the ribbon cartridge.

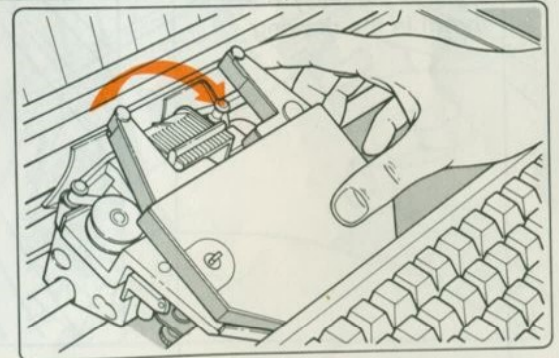

4 Lower the print unit as shown in the drawing.

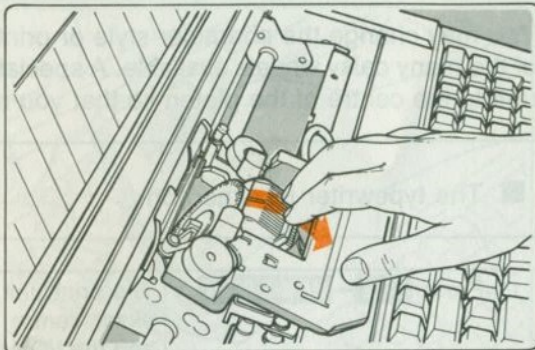

5 Unseat the daisy wheel by pulling up on the central pin.

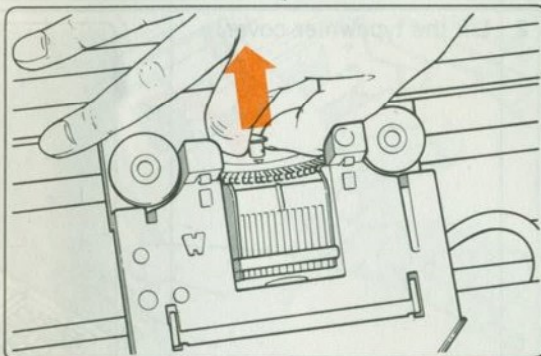

6 Remove the daisy wheel as shown in the drawing.

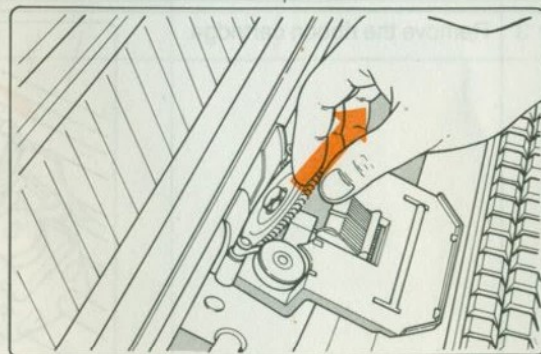

7 Hold the new daisy wheel so the point of the triangle is toward you and press lightly on the central pin.

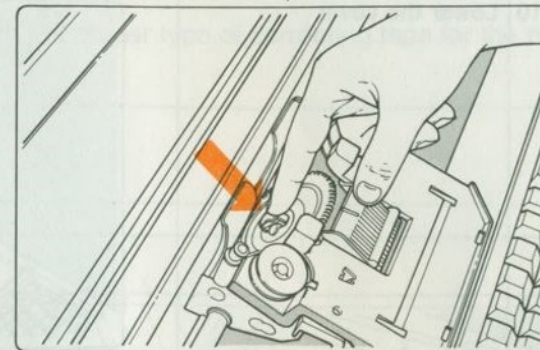

8 Return the print unit to its working position.

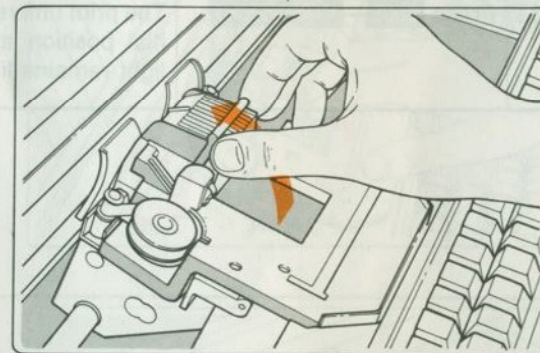

9 Replace the ribbon cartridge.

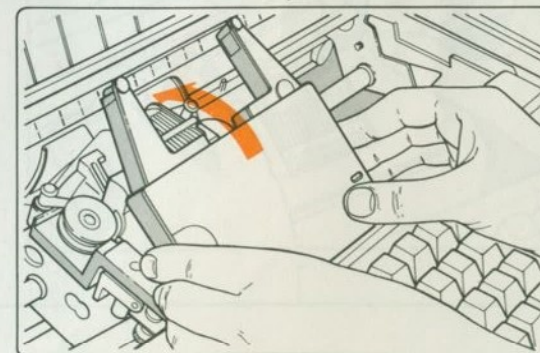

over

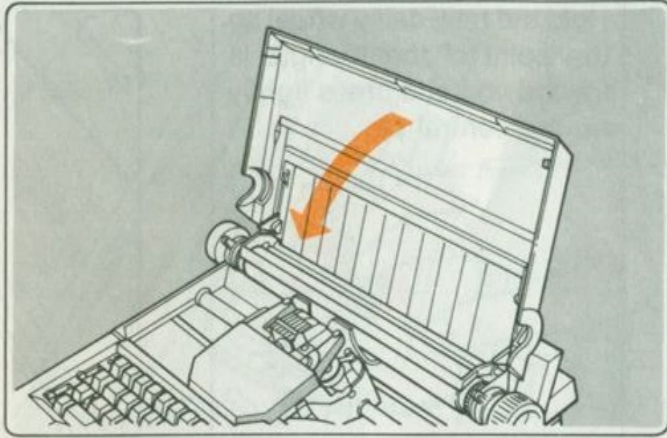

**MARGIN RIGHT** . The print unit return to its initial position and the I/ON light remains lit.

## CORRECTING TAPE

You may correct typing errors with the proper type of correcting tape for the ribbon you are using.



1 Lift the typewriter cover.

2 Remove the ribbon cartridge and lower the print unit as shown in the drawing.

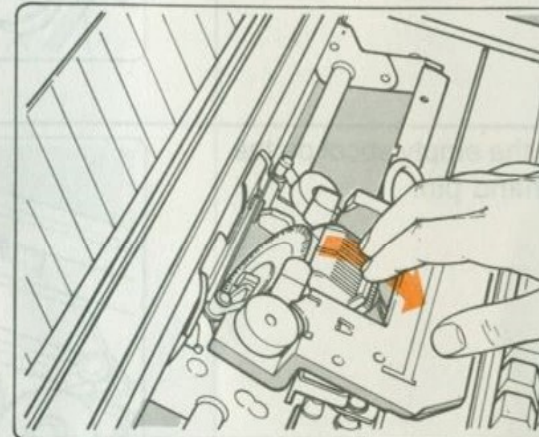

3 Remove the two spools of correcting tape.

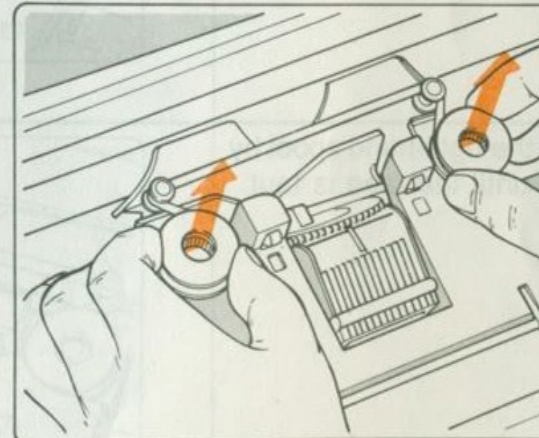

4 Place a new full spool on the left bobbin so that the tape unwinds toward the rear of the typewriter.

Pass the tape behind the left tape guide and unwind it towards the right, passing it behind the right tape guide.

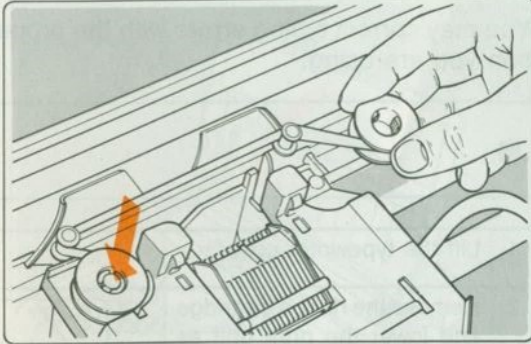

5 Place the empty spool on the right-hand pin.

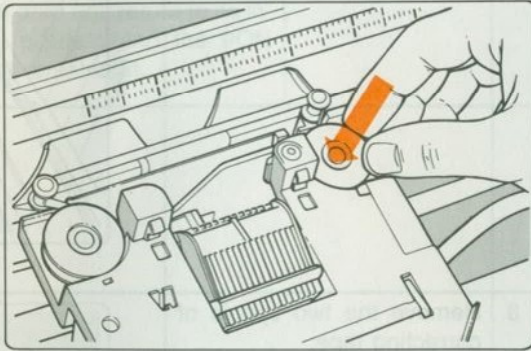

6 Wind the right-hand spool by hand until the tape is taut.

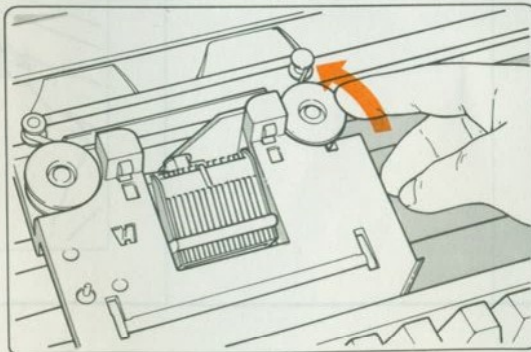

7	Return the print unit to its initial position and replace the ribbon cartridge.		
8	Lower the typewriter cover.		

V <sub>nom</sub>	I <sub>max</sub>	Voltage and frequency
22		100 V - 50 Hz
22		120 V - 60 Hz
23		230 V - 50 Hz
23		240 V - 60 Hz
23		110 V - 60 Hz

Electrical specifications

...table to the right lists all of the various ... in which this product is manufactured, in accordance with national electrical standards.

The equipment contains no FCC Part 15 Class B radio frequency emissions and is designed to prevent radio frequency interference.

The equipment generates and uses radio frequency energy and if not installed and used correctly, it may cause interference to radio or television reception. It has been tested and found to comply with the limits for a Class B computing device pursuant to Part 15 of FCC rules, which are designed to provide reasonable protection against such interference when the equipment is used in a residential environment. If this equipment does cause interference to radio or television reception, which can be determined by turning the equipment off and on, the user is encouraged to try to correct the interference by one or more of the following measures:

- reorient or relocate the receiving antenna;
  - move the equipment away from the receiver;
  - plug the equipment into a different outlet, so that equipment and receiver are on different branch circuits;
  - consult the equipment manufacturer for additional information.
- A check for FCC compliance should be performed before the equipment is used. The user will be notified if the equipment does not comply with the FCC rules. The user will be notified if the equipment does not comply with the FCC rules. The user will be notified if the equipment does not comply with the FCC rules.



## TECHNICAL DATA

Height	12.0 cm (approx. 4.7 in)
Width	41.8 cm (approx. 16.5 in)
Depth	33.3 cm (approx. 13.1 in)
Weight	4.5 kg (approx. 9.9 lb)

### Electrical specifications

The table to the right lists all of the versions in which this product is manufactured, in accordance with national electrical standards.

Voltage and frequency	I <sub>(A)</sub>	P <sub>(W)</sub>
100 V ~ 60 Hz		22
120 V ~ 60 Hz		22
220 V ~ 50 Hz		22
240 V ~ 50 Hz		22
115 V ~ 60 Hz	0.25	

This equipment conforms to EEC Directive 82/499 regarding the prevention and elimination of radio frequency disturbances.

This equipment generates and uses radio frequency energy and if not installed and used properly, i.e., in strict accordance with the operating instructions, reference manuals, and the service manual, may cause interference to radio or television reception. It has been tested and found to comply with the limits for a Class B computing device pursuant to Subpart J of Part 15 of FCC Rules, which are designed to provide reasonable protection against such interference when operated in a residential installation. If this equipment does cause interference to radio or television reception, which can be determined by turning the equipment off and on, the user is encouraged to try to correct the interference by one or more of the following measures:

- reorient the receiving antenna
  - relocate the equipment with respect to the receiver
  - move the equipment away from the receiver
  - plug the equipment into a different outlet so that equipment and receiver are on different branch circuits
  - check that PC board mounting screws, connector screws, and ground wires are well secured
  - check that PC board slot covers are in place when PC boards are not mounted
- If necessary, the user should consult the dealer for additional suggestions. The manufacturer cannot be held responsible for the interference caused by unauthorized modifications to the equipment. Connecting of peripherals not supplied by the manufacturer to this equipment requires the use of grounded shielded cables.

## NOTICE

Ing. C. Olivetti & C., S.p.A. reserves the right to make improvements to the product described in this manual at any time and without prior notice.

The information in this manual is guaranteed to be the most recent available as of its issue date and its proper use is the responsibility of the customer.

Olivetti provides no guarantee (with particular regard to any errors or operating difficulties) and assumes no responsibility for direct or indirect damage resulting from the use of this documentation.

All documentation is copyrighted.